

ROTARY SLOPE MOWER



OPERATION MANUAL Snow Plow SPL01

original Operation manual

revision 02-01-10-2010

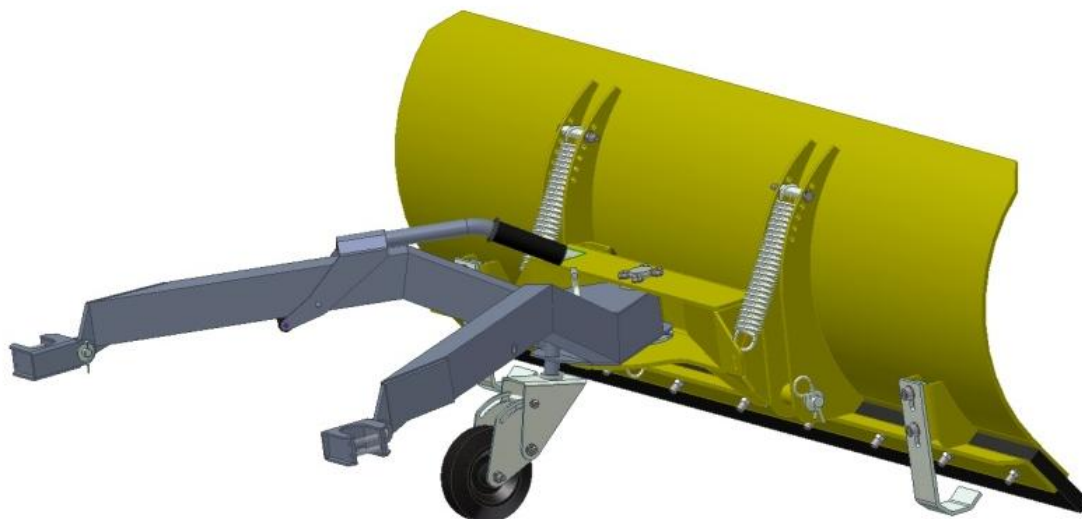

Dvořák – svahové sekačky, s.r.o.
Dvorce 62
Havlíčkův Brod
58001
Czech Republic

Tel: +420 569 425 767
Fax: +420 569 429 239
Mail: info@spider-cz.com
Web: www.spider-cz.com

CONTENTS:

1. Introduction.....	3
2. EC Declaration of Conformity.....	4
3. Product description.....	5
4. Prohibited use.....	5
5. Product identification	5
6. Safety instructions.....	6
7. Safety decals	7
8. Machine / plow delivery.....	8
9. Protective and safety elements of the plow	8
10. Plow installation on a mower	8
11. Controllers	10
12. Plow adjustment.....	11
13. Working with the plow	13
14. Technical description.....	14
15. Basic technical specifications	14
16. Plow maintenance	14
17. Maintenance and lubrication chart.....	14
18. Plow cleaning.....	15
19. Torque chart.....	15
20. Troubleshooting	15
21. After-season maintenance	15
22. Disassembly and liquidation	15
23. Warranty conditions.....	16

1. Introduction

Thank you for purchasing the snow plow SPL01 (further referred to as “plow”). The plow was designed as an accessory to Spider ILD02 slope mower (further referred to as “mower”) and increases the possibility of their application. The meaning of the word “machine” further in the text shall mean Spider ILD02 mower equipped with a snow plow.

Important: The Operation Manual of the plow is an inseparable part of the Operation Manual of Spider ILD02 model. The Operation Manual of the plow describes differences in the mower use while working with the plow! While working with the plow always comply with instructions given in the Operation Manual of the mower as well as in this manual, which describes the use of the snow plow.

The Operation Manual is an inseparable part of the plow. Get acquainted with this Manual while taking over the delivery of your plow and make sure you fully understand everything you need to know. Should you have difficulties understanding any part of this Manual, do not hesitate and contact your local dealer in order to find explanation. Full understanding of and complying with all instructions in this Manual is the basic preconditions for your safe work with this machine.

The Manufacturer reserves the right to make modifications to the plow and the accompanying documentation without a prior notice of such a change and without undertaking any obligation or liability.

The Manufacturer – company Dvorak – svahove sekacky s.r.o. – does not recognize or bear responsibility for any damage caused by the neglect of this Operation Manual.

In several places this Manual contains instructions for safe work. If the text includes such an instruction, then the instruction is marked by the following **WARNING** symbol:



Warning against a highly probable danger of severe injury or life threat if appropriate instructions are not followed

other symbols:



Provides useful information

No part of this document may be further reproduced without a prior written consent of the Manufacturer.

2. EC Declaration of Conformity

DECLARATION OF INCORPORATION OF PARTLY COMPLETED MACHINERY

We manufacturer **DVOŘÁK - svahové sekačky s.r.o.**
Kyjov - Dvorce 62
580 01 Havlíčkův Brod
IČ: 26013797

declare that the product name: **Snow plow**
model: **SPL01**
design for: **additional equipment to the Slope Lawnmower
SPIDER ILD 02, for removing snow**

serial number:

fulfills all the essential requirements of Directive and the technical documentation is
compiled in accordance with part B of Annex VII of

2006/42/EC – machinery

List of technical standards,
specification and harmonised **EN ISO 12100-1,2, EN 13021, EN ISO 14121-1,**
norm used for review of its **ISO 11 684**
conformity

Description

Parameter	Unit	Value
Working width	m	1,4
Angle of plow orientation	°	± 30 (3 positions)
Weight	kg	33

The manufacturer undertakes to transmit , in response to a reasoned request by
the national authorities, relevant information on the partly completed machinery.

Machinery equipment – snow plow SPL01 must not be put into service until the
final machinery into which it is to be incorporated has been declared.

The person authorised to compile the **Jakub Trachtulec**
technical file **Dvořák-svahové sekačky s.r.o.**
Kyjov - Dvorce 62
580 01 Havlíčkův Brod

In Dvorce on 29.12.2009

Dvořák - svahové sekačky s.r.o.
Dvorce 62, CZ-580 01 Havlíčkův Brod
IČO: 26013797 DIČ: CZ26013797



Lubomír Dvořák, owner

3. Product description

The plow was designed as an accessory to Spider ILD02 slope mowers. Its function is to shovel snow during winter maintenance.

4. Prohibited use



The plow must not be used:

- if any part of the plow is damaged or shows signs of significant wear and tear, e.g. pivots, rubber blade, lifting wheel etc.
- on public thoroughfares with possible occurrence of transport vehicles.



Further it is prohibited:

- to mount the plow on other types of mowers or other equipment
- to use the plow for shoveling other material than snow
- to use the plow on slopes exceeding 15 degrees
- to use the plow in areas with terrain obstacles, which could damage the plow or the mower
- to use the plow in areas with insufficiently firm ground where the machine could be rolled over or otherwise damaged
- to use the plow and the mower on icy ground
- to use the plow together with other attachments and devices of the mower (hydraulic winch, engaged cutting device etc.)

5. Product identification

The plow can be identified by the serial number, which is listed on the factory label. The serial number must be provided during every request for servicing and with every order of spare parts.

position of the factory label on plow	factory label









6. Safety instructions

- The plow may only be used together with SPIDER slope mower model ILD02
- The mower must be complete, with all covers, undamaged by previous operation and fully functional.
- When using the plow the operator must respect and follow the Operation Manual of the SPIDER ILD02 slope mower, which is an inseparable part of the Operation Manual of the plow. The Operation Manual of the plow only describes differences in the use of the mower while working with the plow. These differences must be respected by the operator.
- The operator must be acquainted with both the plow and mower operation and their Manuals.
- The operator of the plow and the mower must at all times fully concentrate on safe operation of the these devices, and must not be under the influence of alcohol or drugs, which influence perception and attention.
- The Manual must be stored at a place permanently accessible to the operator and must be available to him at any time.
- Never allow children and unauthorized or untrained people to use the product.
- The plow may only be used on areas without obstacles, bushes, trees, sharp rocks and other objects and obstacles, which could damage the plow or the mower.
- The operator is responsible for any damage caused to third parties by operating the machine.
- Do not remove or damage any of the safety labels placed on the plow.
- Do not remove any covers or safety elements from the plow. They are here for your protection.
- Do not use the plow if any of the protecting devices or covers are damaged or missing.
- Keep the plow and its accessories clean and in a good technical condition at all times.
- It is strictly prohibited to make any changes or modifications to the plow that were not previously approved by the manufacturer. Any modification to the plow or replacement of any of its parts by an unapproved component may lead to a hazardous situation or injury. If these instructions are not followed, the manufacturer does not bear any liability for the machine.
- The operator/user is responsible for the safety of persons that enter the working area of the machine. Immediately interrupt your work and stop the machine if third persons approach or enter the working area.
- Obey all plow maintenance instructions listed in this Manual.
- Maintenance or any other work on the plow may be performed only when the machine is turned off.
- Keep the plow clean by brushing and wiping it after use. Do not use gasoline/petrol or similar products for cleaning.
- Do not use the plow if you are under influence of alcohol, drugs or medicaments influencing perception.
- While using the machine the operator's position must never be in front of the plow in the possible path of movement of the machine. The operator also must not stand below the machine or directly above it or in the working area of the plow due to danger of injury if the machine falls down or if the operator slips and falls under the machine.
- Never enter the space between the plow and the mower.
- When using the plow, follow all general work safety regulations.
- Work with the machine may only be started if the mower and the plow are not damaged by previous operation.
- Do not reach with your hands or feet to the working area of the plow and do to attempt to help the machine by e.g pushing it.
- It is prohibited to use the snow plow and the hydraulic stabilizing winch at the same time.
- It is prohibited to engage the mowing device of the mower while the plow is mounted on the mower.
- While working with the plow always remain at a safe distance from the machine, where you cannot be hit by objects accidentally thrown by the machine or by an undesired movement of the machine such as its fall or sliding.
- Never approach the machine from above – danger of slipping and falling under the machine.
- Never enter the area below the machine or directly above it and ensure that no other persons enter this area.
- Stop working with the machine if the other persons or animals enter the dangerous area of the machine, that means the area in front of the plow in the direction of possible movement of the machine, area below the machine, directly above the machine and the working area of the plow.
- Any adjustment or maintenance of the machine may only be performed when the machine is stopped, mower engine turned off and the mower is secured against movement.
- If you are reaching under the plow, make sure it secured against dropping of falling.

7. Safety decals

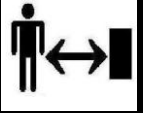
This chapter is devoted to the safety label symbols (pictograms) used on the plow and their meaning. Under each symbol you will find a number of the position of the label on the plow. Safety labels inform the operator about risks while using the plow. Understanding their meaning and obeying the given instructions will make the use of this plow safe.

			
			
1	2	3	4
Read the Operation Manual before use	Danger of hand or foot crushing	Do not enter this area	Danger of hand or foot getting caught

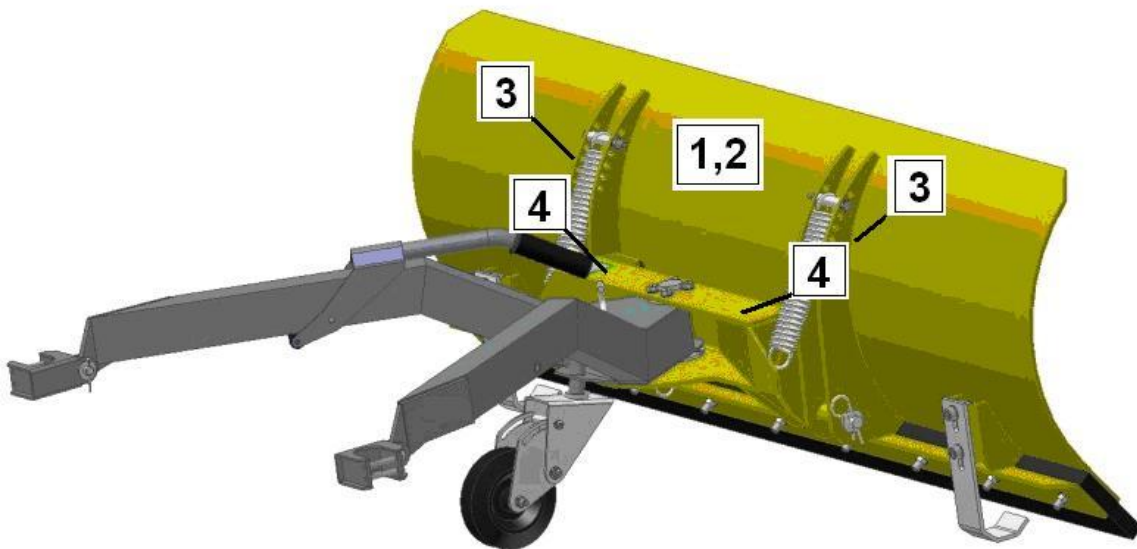

8. Machine / plow delivery

The plow is not delivered by the manufacturer as part of the mower and with an order of a new mower the plow will not be attached to it. The plow may be ordered as an optional attachment for SPIDER ILD02 mower.

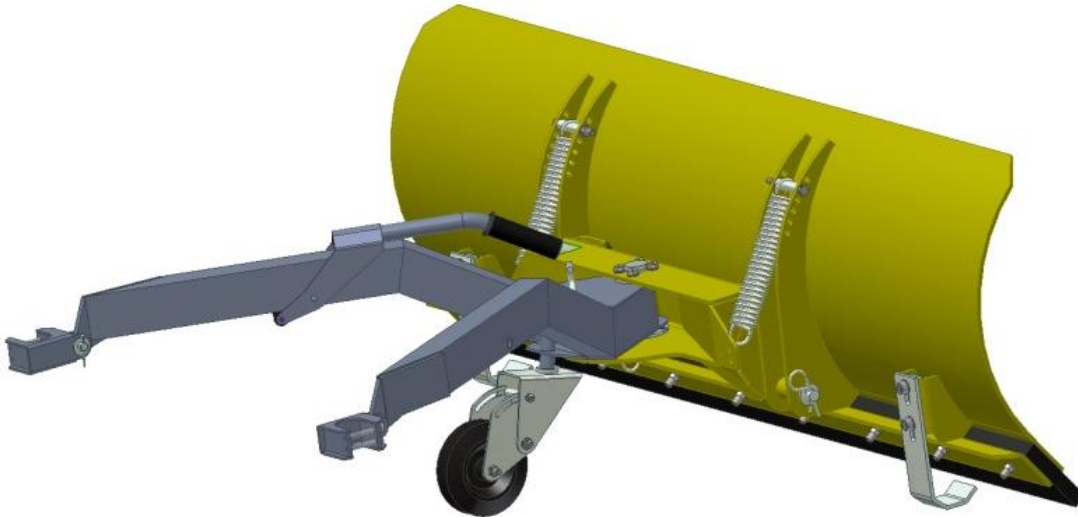

9. Protective and safety elements of the plow

The plow is attached to the mower in such way, which eliminates health and safety risk to the operator and third persons as well as to their property. The plow is equipped with springs, which – in case the plow hits an obstacle – absorb the shock and thus protect the machine from excessive damage. For correct function of the plow these springs must be properly mounted.

For correct function of the plow it is also necessary to have the guide tongues and lifting wheel well adjusted.







The adjustment of guide tongues and the lifting wheel must be changed according to the wear of the rubber blade.

The adjustment of the guide tongues and the lifting wheel must be checked daily.

The rubber blade must be changed if excessively worn

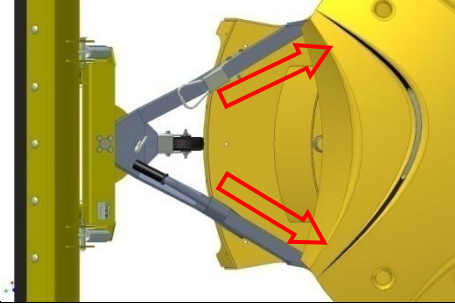
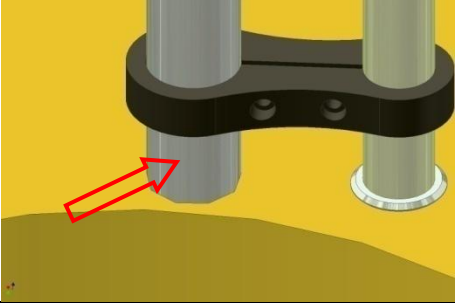
10. Plow installation on a mower

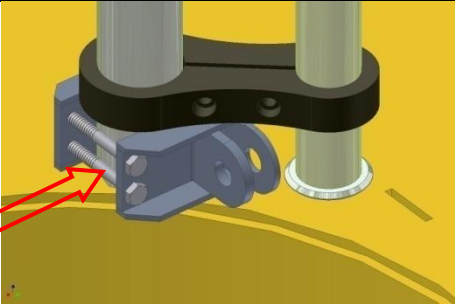
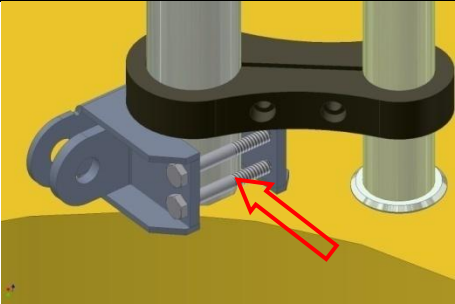
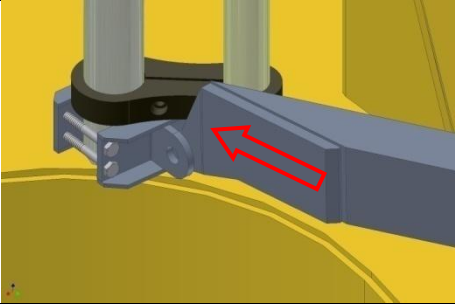
- Use two brackets in order to attach the snow plow to the sliding bars of the mower on the side of hydraulic tank. .
- Slip the brackets on the sliding bars between the main deck of the mower and the stiffener of the sliding bars.
- Use two bolts to fasten the brackets to the sliding bars.
- Use two pivots and pins to attach the plow to the brackets.

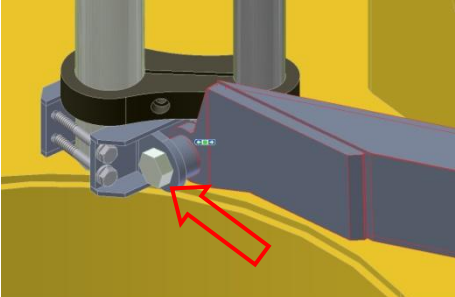
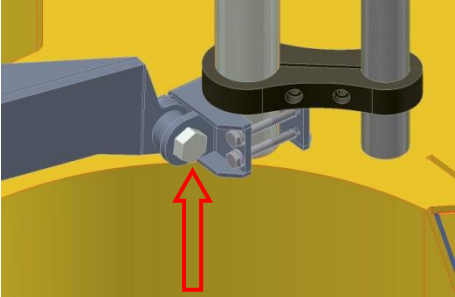
Place of plow attachment on the mower	Place of bracket attachment on the sliding bar
	
Left side	Right side
Slip the bracket on the sliding bar between the main deck and the stiffener	
	
Use two bolts to fasten the bracket on the sliding bar	
	
Attach the plow between two eyes of the bracket	
	
Use pivots to secure plow and tighten them with a torque of 25Nm	
	



Before use check the tightening of all bolts and nuts

11. Controllers

Lifting lever is used for the lifting the plow and for securing it in the transport position. The plow is not functional in this position.



Pay increased attention to the manipulation with the machine with the plow in the transport position. The lifting lever must be in its top limit position otherwise it may get loose and cause the plow to fall down.

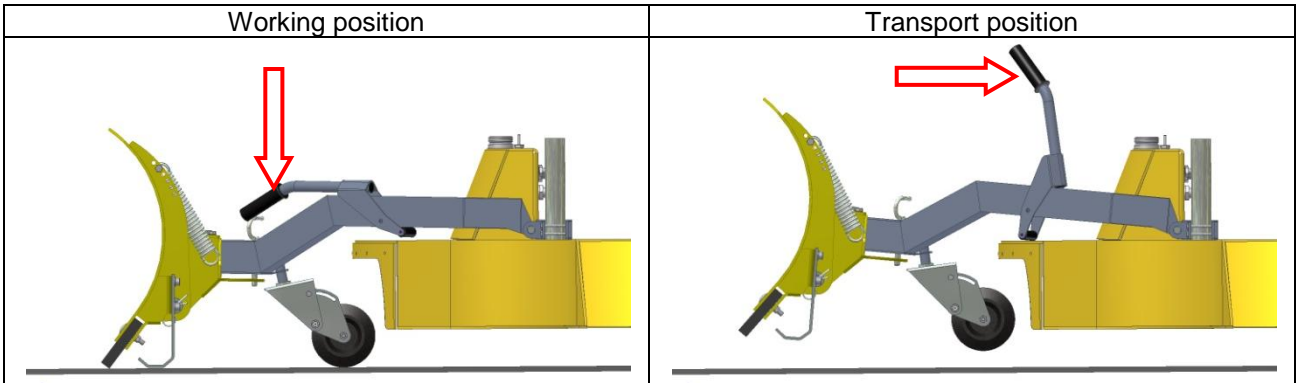

Positioning lever is used for the locking of the plow in three positions (0°, +30°, -30°). The change of plow positioning may only be performed when the plow is lifted. By lifting the positioning lever the plow unlocks and can be manually rotated into the required position. After a new position is selected the positioning lever must be locked again.



The plow must always be locked in one of its three positions. Improper locking may result in plow or mower damage.

While positioning the plow, do not put your hands or feet between the frame and the moving parts of the plow – danger of crushing or other injury.

Make sure that the plow is properly locked after it has been set into the working position.

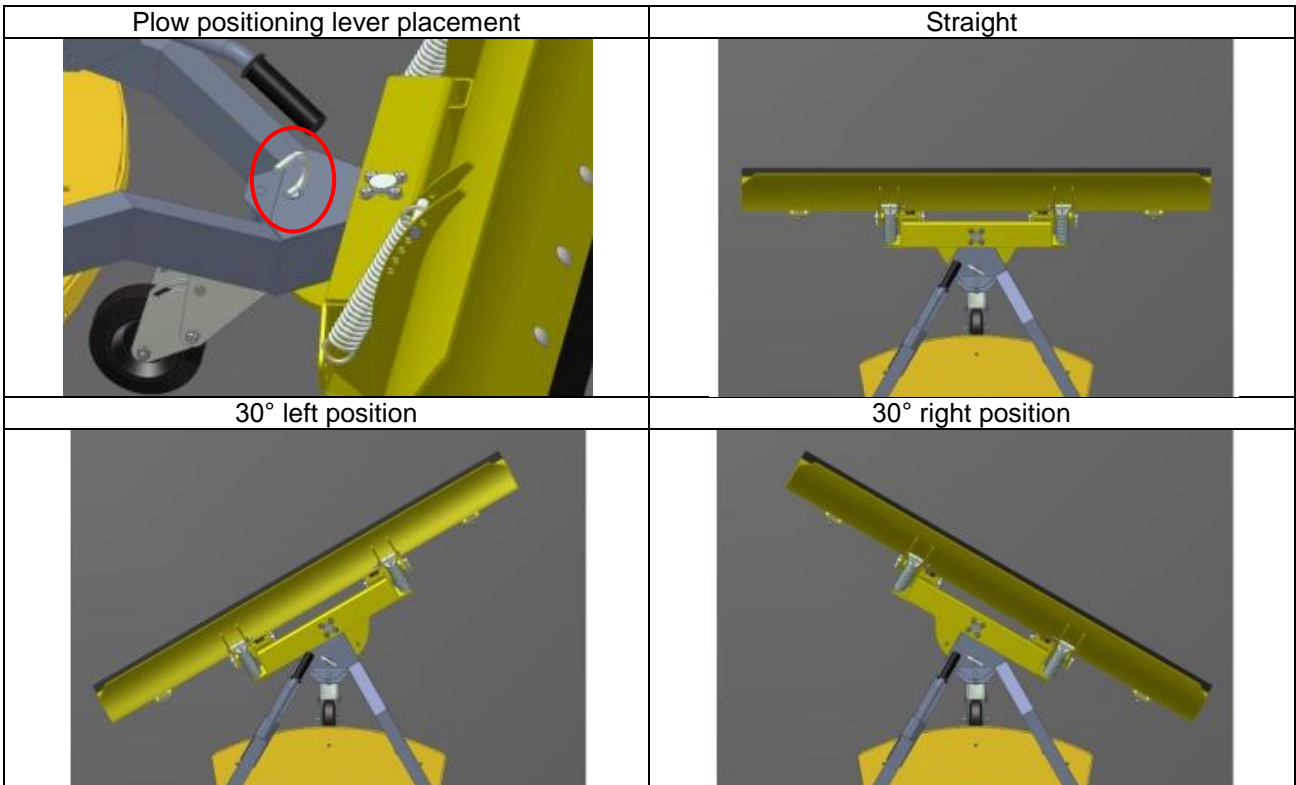



12. Plow adjustment

In order to function correctly the plow requires proper adjustment of the guide tongues and the lifting wheel.



During plow adjustment the engine of the mower must be turned off and the mower must be secured against accidental starting and undesired movement.

The adjustment of the guide tongues and the lifting wheel may only be performed when the machine is set to the minimum height of cutting. With other height setup the plow cannot be adjusted correctly.

While adjusting the plow, always use suitable tools in order to prevent the plow from dropping down accidentally and injuring your limbs.

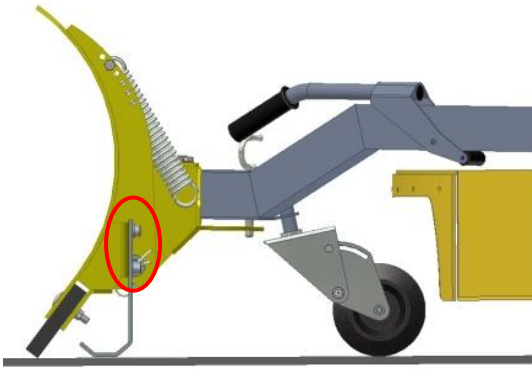
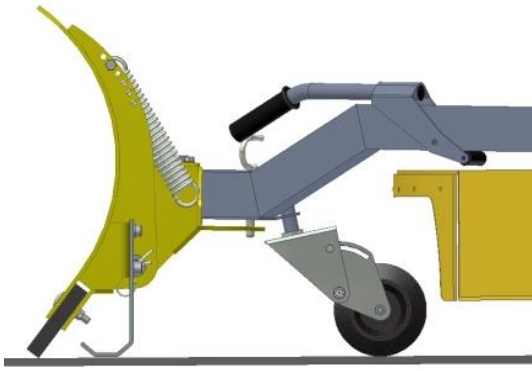
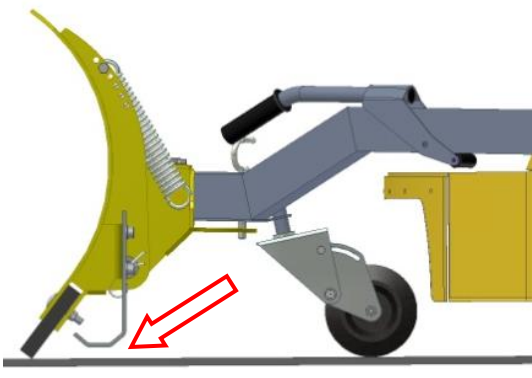
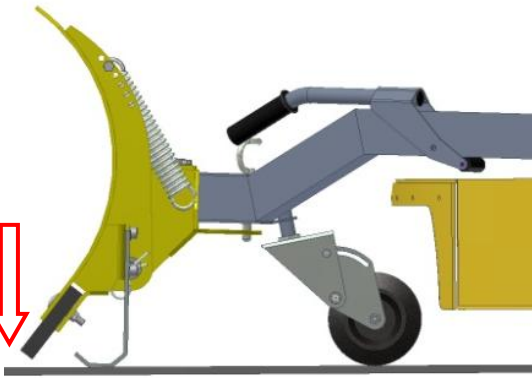

Guide tongues

- set the machine to minimum height of cutting
- loosen two bolts attaching guide tongues so that the guide tongues can move freely
- turn the lifting wheel is such position where the rubber blade of the plow lies on the ground
- move the guide tongues down so that they lie on the ground as well and tighten the two bolts of the guide tongues.

Position of the guide tongue bolts	Correct adjustment (lifting wheel, rubber blade and the guide tongues are lying on the ground)
	
Incorrect adjustment (guide tongue is too high)	Incorrect adjustment (guide tongue is too low)
	

Lifting wheel

- adjust the machine to the minimum height of cutting position
- turn the lifting wheel so that rubber blade of the plow touches the ground
- loosen the bolt securing the position of the lifting wheel and thus release the movable part of the lifting wheel
- during adjustment the lifting wheel must be turned toward the machine
- in this position adjust the wheel so that it touches the ground while the rubber blade of the plow stays on the ground as well
- tighten the bolt of the lifting wheel

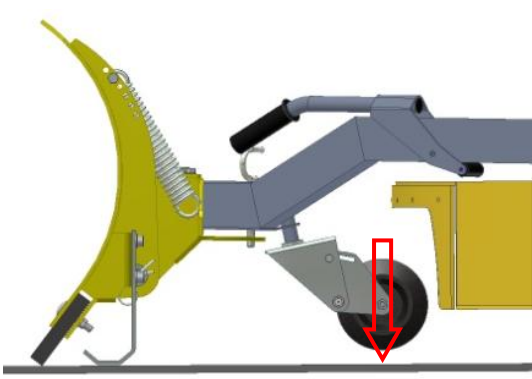
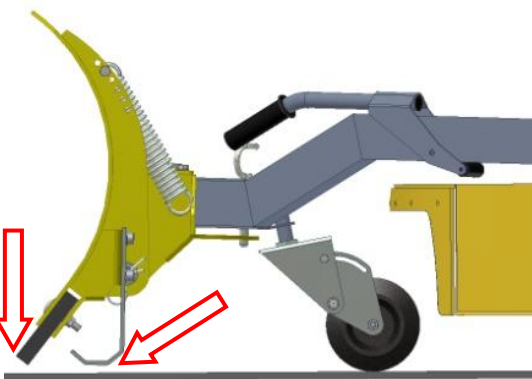
Position of the adjustment bolt of the lifting wheel	Correct adjustment (lifting wheel, rubber blade and guide tongue are touching the ground)
	
Incorrect adjustment (lifting wheel is too high)	Incorrect adjustment (lifting wheel is too low)
	

13. Working with the plow

Driving with the plow is very demanding for the operator as they constantly have to evaluate information about the movement of machine and the character of the terrain. Especially important is wheel adhesion to the surface.

Maximum climbing ability of the mower with a plow is 15 degrees.



- Examine closely the working area. Get orientated, evaluate the situation and test the possibilities and characteristics of the specific terrain. Do not take chances. You must be well acquainted with the terrain before you start to work.
- If the mower is slipping, do not try to stop it and do not approach it, especially the areas below the mower and directly above it.
- While operating the mower always stay at a safe distance from the mower. Never stay right next to the machine (in any direction), in the potential path of movement of the machine nor in areas to which the machine might slip or fall. Before you start to work make sure that no persons are present below or above the machine or in the working area. Do not endanger third persons or their property by the movement of the mower.
- Choose your operating position away from the area to which the mower may slide or fall.
- While working with the plow it is prohibited to use the hydraulic stabilising winch or to engage the cutting device of the mower.
- Do not drive the plow to bushes, curbs or similar obstacles.
- When working with the plow avoid sudden sharp changes of direction or driving speed.

Working procedure



- Make sure the plow is correctly attached to the mower
- Make sure that the machine is correctly adjusted
- Set the height of cutting of the mower to the lowest position
- Use the lifting lever to bring the plow to the working position (the plow must lie on the rubber blade as well as on the lifting wheel)
- While driving forward the lifting wheel will turn automatically and lay the tuber blade on the ground.
- While driving backward the lifting wheel will automatically lift the plow so that you can drive without the rubber blade touching the ground.
- During work it is also possible to lift the plow by using the height of cut adjustment switch on the remote control
- The plow will function correctly only if the mower is set to the minimum cutting height
- Use the lifting lever if you want to set the plow to the transport position
- While moving the machine from one location to another, the plow must be in the transport position.



If the above paragraph mentions height adjustment of the cutting device it is only for the purpose of plow adjustment. Under no conditions this should be understood as a procedure leading to the engagement of the cutting device.



When working with the plow it is prohibited to:

- stop the machine on slopes. The machine may uncontrollably drive / slide down the slope.
- stay right next to the machine, in the area below the machine or directly above it.
- use human force for machine stabilization or movement
- work on slopes with tilt exceeding 15 degrees
- drive into firm obstacles
- use the plow for shovelling of other materials than those for which the plow was designed

14. Technical description

The plow is composed of:

- Plow body
- Plow frame
- Sliding bar bracket

The frame and the body form the main structure of the plow, which is attached to the frame of the machine by sliding bar brackets. The plow frame carries the lifting wheel (used for plow lifting when driving backward), lifting mechanism (for securing the plow in a transport position) and a mechanism for plow adjustment in 3 positions. The plow body is fitted with adjustable guide tongues, rubber blade and a safety spring-loaded tilting mechanism, which eliminates mechanical stress when the plow encounters a firm obstacle.

15. Basic technical specifications

Parameter	Unit	Value
Weight	kg (lbs)	33 (72)
Working width	m (inch)	1,4 (55)
Angle of plow orientation	°	± 30° (3 positions)

16. Plow maintenance

The plow as a mower accessory is not demanding in terms of maintenance, but requires regular maintenance

- Keep the plow clean
- Follow the lubrication schedule of the plow
- Check proper tightening of bolts and nuts
- Check the wear of individual components and ensure necessary exchange in time
- Check correct adjustment of the guide tongues and the lifting wheel



Plow maintenance may only be performed when the machine is standing still, mower engine is turned off and the “STOP” button on the mower is pushed down. In case you intend to reach under the lifted plow, make sure to support the blade with a suitable wooden block, which will prevent the plow from falling down.

17. Maintenance and lubrication chart

Action / intervals in hours	Before operating	every 100 hours
	Check bolt tightness	•
Check wear of functional parts	•	•
Clean the plow	•	•
Lubricate pivots of moving parts of the plow		•
Check and adjust guide tongues		•
Check and adjust lifting wheel		•

Lubricants:

- grease (◆)
- chain spray (□)

18. Plow cleaning

After each shift clean the plow surface. Clean surface helps to prolong the service life of the device and maintain its correct functioning. Dirt can be cleaned with a broom or water. In case you use water for cleaning, make sure to treat functional surfaces according to the lubrication schedule.

Do not use gasoline or other oil products for cleaning.



Plow maintenance may only be performed when the machine is standing still, mower engine is turned off and the “STOP” button on the mower is pushed down. In case you intend to reach under the lifted plow, make sure to support the blade with a suitable wooden block, which will prevent the plow from falling down.

19. Torque chart

Bolt	M 6	M 8	M 10	M 12	M 14	M 16	M 20
Tightening torque /Nm/	10	25	50	85	135	215	410

20. Troubleshooting

Problem	Possible cause	Remedy
plow leaves behind unshoveled layer of snow	terrain is too frozen	use different method for removal of frosts
	plow is lifted in transport position	use the lifting lever to bring the plow to the working position
	Machine is not set to minimum height of cutting	adjust the machine to the minimum height of cut position by the remote control
	Incorrectly adjusted guide tongues	adjust guide tongues
	incorrectly adjusted lifting wheel	adjust lifting wheel
	excessively worn rubber blade	change the rubber blade for a new one
plow does not lift when driving backward	incorrectly adjusted lifting wheel	adjust lifting wheel
	excessively worn lifting wheel	change the lifting wheel for a new one

21. After-season maintenance

After season or if the plow is not used for more than 1 month it is suitable to prepare it for storage. Perform checks according to the maintenance schedule and hours in use.

- thoroughly clean the whole plow
- change defective or worn parts
- check all bolted connections. Tighten all loose nuts and bolts.
- Lubricate all moving parts (follow the lubrication schedule)
- store the machine at a dry place



Plow maintenance may only be performed when the machine is standing still, mower engine is turned off and the “STOP” button on the mower is pushed down. In case you intend to reach under the lifted plow, make sure to support the blade with a suitable wooden block, which will prevent the plow from falling down.

22. Disassembly and liquidation

The plow consists mainly of metal parts (iron and aluminium) which form the frame and the body of the plow. After the end of the service life of the plow we recommend to separate plastic parts (mainly covers), metal parts and rubber parts and hand them over for recycling to specialized facilities.

When disposing of the plow you must follow all rules and statutory regulations for waste disposal.

23. Warranty conditions

This document sets out the extent, conditions and manner of exercising rights stemming from the Manufacturer's liability for defects of the delivered Product

1. Dvořák – svahové sekačky Ltd., registered office Dvorce 62, Havlíčkův Brod 58001, Czech Republic, ID No. 2601379 (further referred to as "Manufacturer") provides a Warranty for new Products according to the set regulations for a period of 24 months from the day the Product is delivered to the Customer, or from such a Product being set into operation, or up to 800 operating hours, according to whichever happens first. The Warranty period for new spare parts delivered under Warranty expires together with the Warranty period of the whole Product/machine.
2. Claims stemming from the Warranty must be exercised with the Distributor / Dealer and also resolved by them. A properly completed Warranty sheet must be presented and all of the inspections prescribed by the Manufacturer must have been implemented. Incorrect information, additional extracts or overwriting on the Warranty card lead to loss of the Warranty.
3. The Warranty applies to defects on the Product caused by defective raw materials, construction faults or made workmanship. Defective parts on the Product will be replaced free of charge with a new part or repaired. No entitlement to immediate delivery is created and the Manufacturer takes on no liability for damage claimed for as a result of delayed delivery.
4. The Warranty does not relate to regular wear and tear (parts susceptible to regular wear and tear especially include the following: blades, blade hubs with bearings, bearings of wheel shafts, spark plugs, air filters, belts, chains, tires, sealing, hydraulic hoses, winch rope etc...).
5. The Warranty cannot be claimed against if the cause of the defect is:
 - a) The effects of external mechanical or chemical influences on the Product
 - b) Unreasonable handling of the Product, overloading it, neglect or incorrect operation
 - c) Repair of maintenance of the Product performed by a third party, which was not authorised to carry out such work by the Distributor / Dealer or Manufacturer
 - d) Installation of such parts into the Product, the use of which is not approved by the Manufacturer
 - e) Implementation of changes to the Product, which were not approved by the Manufacturer
 - f) The fact that the Manufacturer's regulations were not adhered to for handling the Product, its maintenance and treatment (e-g. the instruction and maintenance manual), especially if the prescribed Warranty inspections were not carried out
 - g) The fact that the user neglected declaration and removal of defects, which were apparent when they took receipt of the Product or which they did not immediately provide notification of an have removed, when they arose later
6. In case of Products sold with a discount the Warranty does not extend to defect for which the discount was granted.
7. All claims stemming from the Warranty are forfeit on expiry of the Warranty period. In the case of defects, for which notification was made during the course of the Warranty period and which were not removed during this period, this Warranty remains valid until the defect is removed. In this case, the Warranty is terminated at the latest within 1 month of the last repair or after declaration by the Distributor / Dealer that the defect was removed or that this does not concern a defect.
8. The Manufacturer is not liable for any economic loss or for any subsequent damage caused to persons or their property, which was created as a result of failure of the Product.
9. The Warranty will only be valid subject to the condition that the correctly completed part 2 of the "Combined delivery note" is delivered to the Manufacturer within 14 days of the date the Product is delivered to the Customer.
10. The Warranty applies to the Product in the condition in which it leaves the production plant. The Manufacturer is not liable for damage during transportation.
11. In the event of a change in owner, it is possible to transfer the remaining part of the Warranty period to the new owner if the Manufacturer is requested to do so. The new owner confirms that they have taken

receipt of the instruction manual at the same time as the Product as well as the Warranty conditions and that they agree with these.

12. The Warranty period is extended by the period of the duration of the Warranty claim assessment. (The Warranty claim assessment period begins on the day following the day the Product is accepted for assessment and terminates on the day the Warranty is acknowledged or rejected, not on the day the Customer collects the Product back). In case the Warranty claim is rejected, the Warranty period will not be extended!
13. After inspecting relevant documents and the claimed product the Distributor / Dealer will:
 - a) acknowledge the Warranty claim as warrantable and settle the claim on spot; in case it is not possible to settle the acknowledged claim on spot, they will accept the Product into Warranty procedure during which the acknowledged claim will be settled without unnecessary delay. The Distributor / Dealer will issue a written document certifying the acceptance of the Product from the Customer and both parties will confirm it by their signatures; or
 - b) reject the Warranty claim as unwarrantable and together with the Customer they will agree on further steps, or
 - c) accept the claimed Product for a professional assessment based on which the warranty claim will either be acknowledged and consequently settled without unnecessary delay, or rejected. The Distributor / Dealer will issue a written document certifying the acceptance of the Product from the Customer and both parties will confirm it by their signatures. The Distributor / Dealer will inform the Customer about the result of the assessment (acknowledgement or rejection of the Warranty claim) in a previously agreed manner (in writing or by one of long-distance communication devices).